

Controlli Elettronici per Passerelle e Limitazione del Carico per Gru

***Gangways Electronic Controls and
Cranes Rated Capacity Indicators***

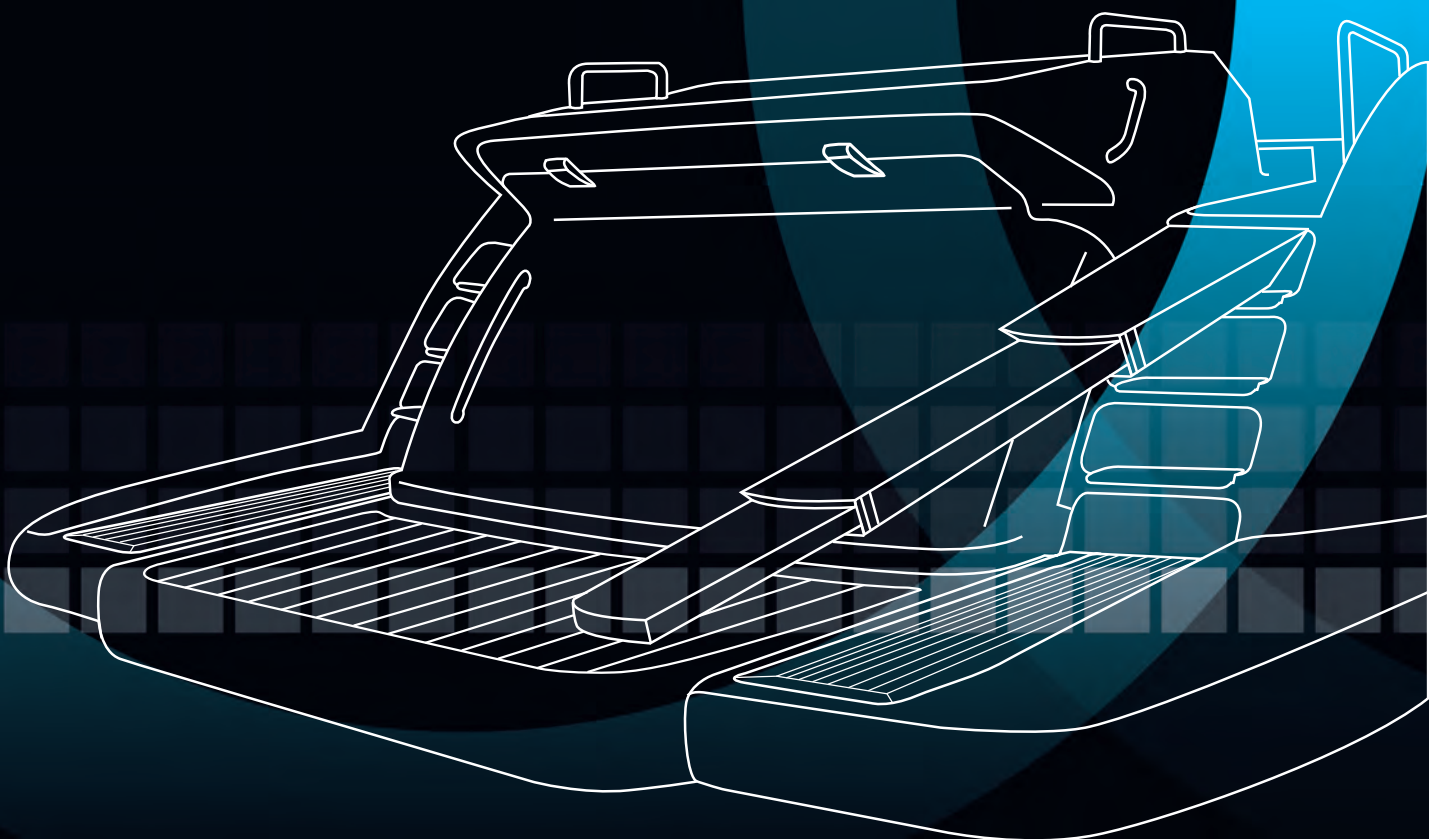



■ Centralina di Controllo Master CAN BUS | IO-EXT
CAN BUS Master controller | IO-EXT



■ Ricevitore Telecomando CAN BUS
CAN BUS Remote Control Receiver



■ Sensore Angolare CAN BUS: AMU
CAN BUS Angle Sensor: AMU



■ Telecomando
Remote Control

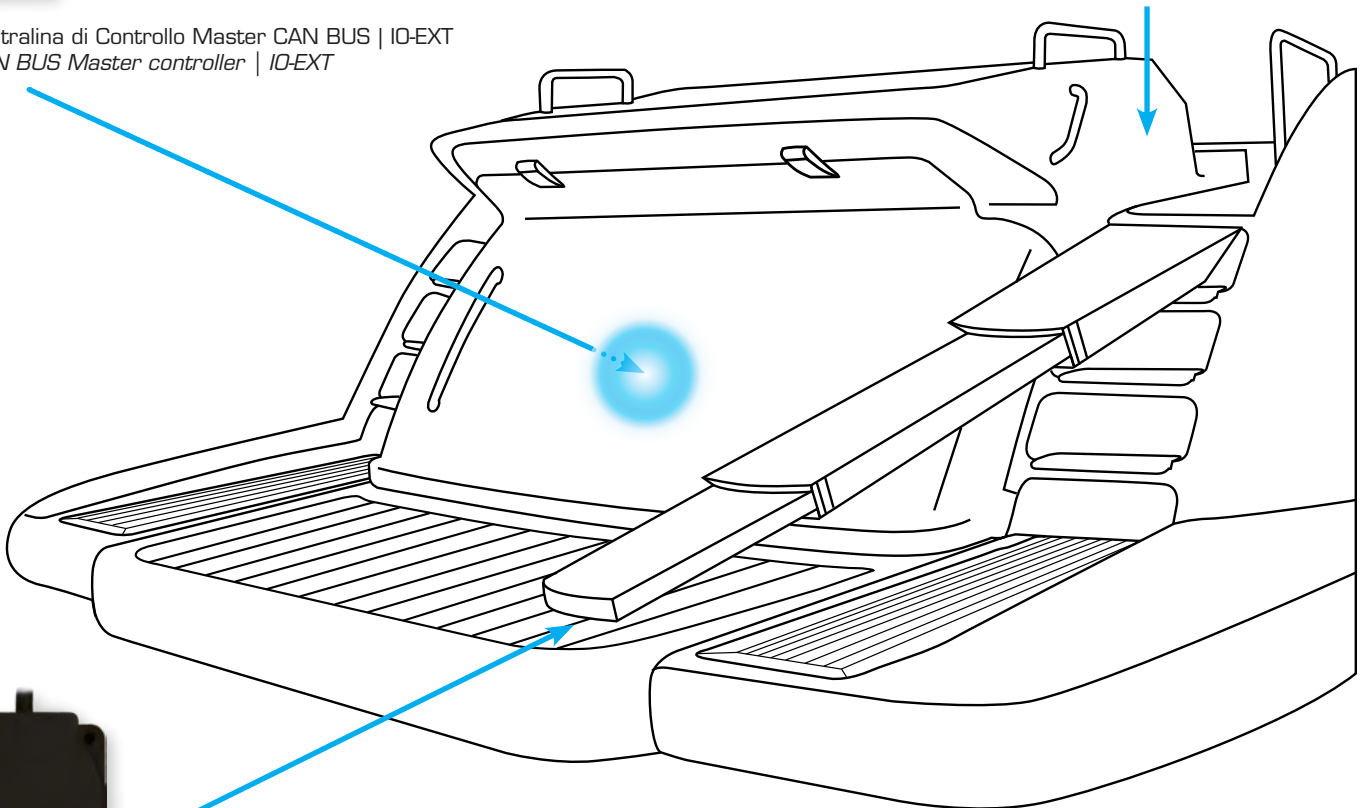

Caratteristiche

- Sistema Modulare per Controllo Passerelle
- Adatto per Piccoli Movimenti e Movimenti Multipli della Passerella

Features

- *Modular System for Gangways Control*
- *Suitable for Small and Multi-movements Gangways*



Limitazione del Carico per Gru *Cranes Rated Capacity Indicators*

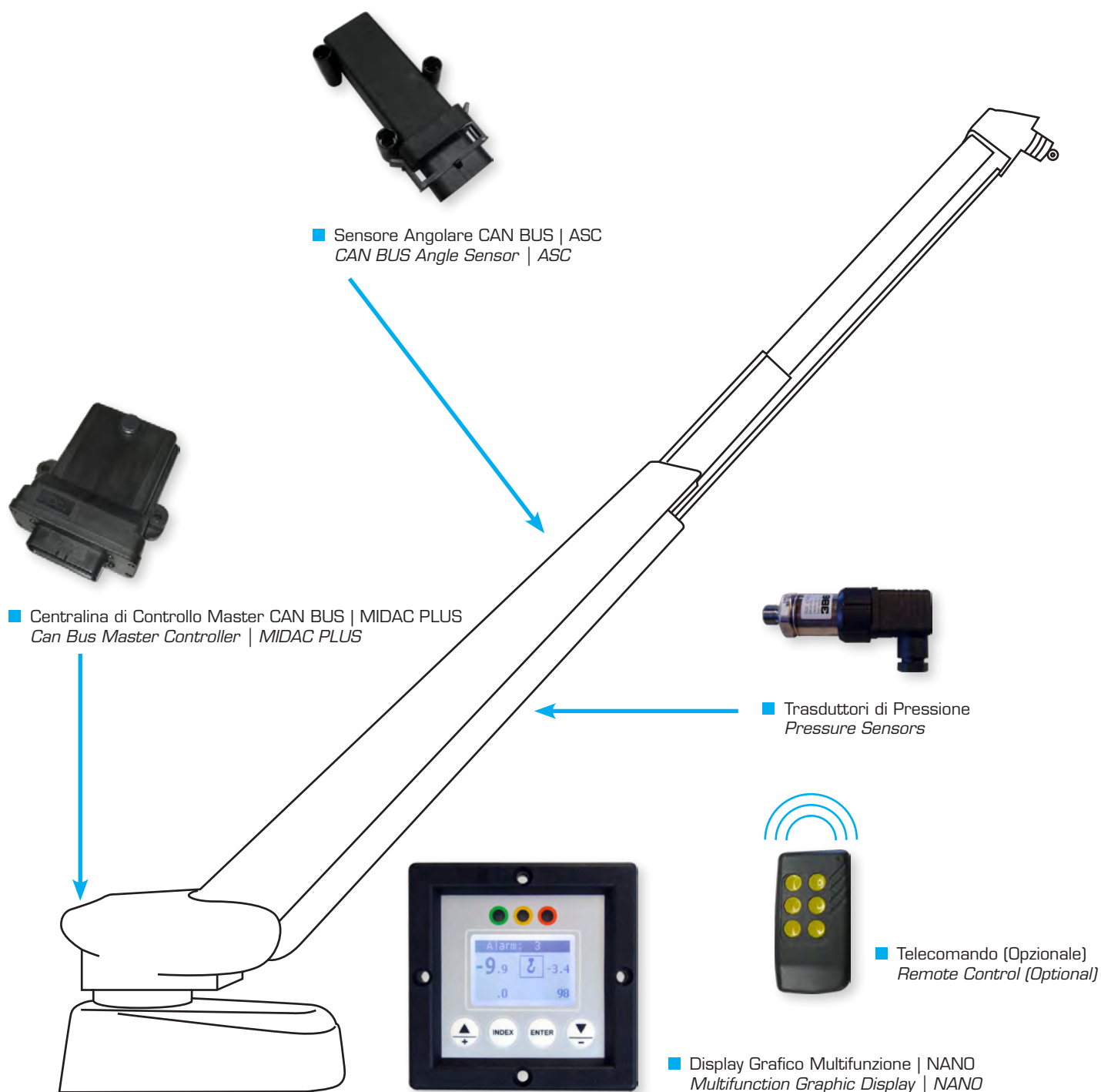

Caratteristiche

- Controllo Movimenti
- Controllo Carico Massimo
- Telecomando (Opzionale)

Features

- *Movements Control*
- *Maximum Load Control*
- *Remote Control (Optional)*



Headquarters:

Via Tito Speri, 10

25024 Leno (Brescia) ITALY

Tel. +39 030 90451

Fax +39 030 9045330

info@cobospa.it

www.cobospa.it